



**SUPER
BOOST•ALL** 
Goodall

12/24V

With Protect•All®

12/24V Integrated Vehicle Mount, Battery Powered Jump Starting with Advanced System Protection!

Ideal for small to medium duty fleets, the integrated Super Boost•All® 12/24V with Protect•All® is designed for mobile applications, with integration to your service vehicle's high idle function for higher charging and increased jump starting power. The Super Boost•All® is equipped with intelligent technology that enables 12V service vehicles to jump start 12V or 24V vehicles without compromising the service truck. Featuring the best protection in the industry, the Super Boost•All® provides protection from reverse polarity, dead shorts and open clamps. It also offers 12V and 24V mode lockout for additional safety.

SPECIFICATIONS

Jump Starting	12/24V
Power Source	2 or 4 Group 31 Batteries
Cables	25' 2/0 ga.
Clamps	1,000A

Super Boost•All® with Protect•All® 150 Unit Dimensions (In.): 16W x 9D x 17H
Dry Weight (Lbs): 48

FEATURING:



Look for the logo that delivers built-in safety!

The innovations in safety technology include: reverse polarity, low voltage protection, short circuit, overheat protection, over discharge protection, over voltage protection, and open-clamp protection.



We Start Engines™

SUPERBOOSTALL_092923_NML



12/24V
With Protect•All®

FEATURES

- Digital Display for Reading Ease
- Alternator Separator Function to Prevent the Service Vehicle Batteries From Draining During Jump Starts
- Keeps Auxiliary Batteries at Full Power and Ready for Jump Starting
- Allows for Faster Jump Starting of Vehicles
- Provides High Idle Signal for Increasing Alternator Output and Jump Starting
- Serviceability Ease

PROTECT•ALL® TECHNOLOGY

- Reverse Polarity Protection
- 12V and 24V Mode Lockout to Prevent System from Engaging if Receiving Voltage Does Not Match
- Dead Short Protection
- Open Clamp Protection

KIT INCLUDES

- Control Box
- 25 ft. Booster Cables
- Battery Separator

OPTIONS/ACCESSORIES

- Battery Box with 110VAC Charger
- Connecting Cables
- Horizontal Mounting Kit
- Group 31 AGM Batteries
- Boost Cables
- Boost Cable Clamps

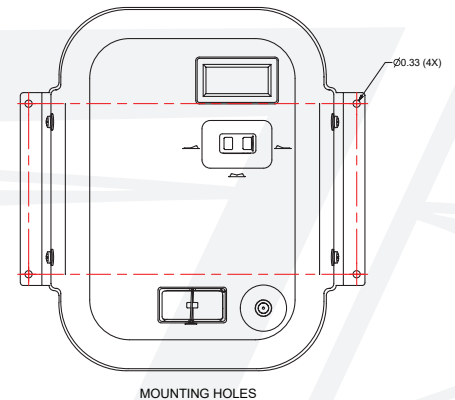
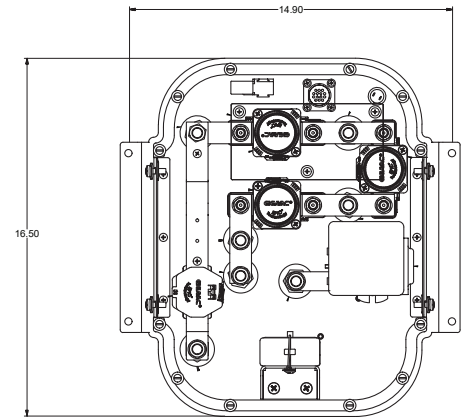

MOUNTING HOLES

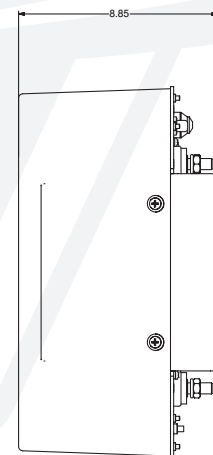

Vanair® reserves the right to make changes in engineering, design, and specifications; add improvements; or discontinue manufacturing at any time without notice or obligation. Goodall®, the Goodall® logo, and WE START ENGINES® are registered trademarks or trademarks of Vanair® Manufacturing, Inc., Michigan City, IN, USA. © 2023 All Rights Reserved.



We Start Engines®

800.526.8817 | vanair.com

10896 West 300 North | Michigan City, Indiana 46360 USA



SUPERBOOSTALL_092923_NML