



**VIPER**   
**DIESEL**

 AIR COMPRESSOR

## Smart, Fuel Efficient, Powerful and Dependable Air Power!

With the Vanair® Viper™ Diesel you get all the air power you need to get the job done at half the cost of tow behinds or cross mounts. Engineered with smart technology to provide automatic variable speed control for fuel savings, the Viper™ is perfect for running 90 lbs. jackhammers, operating up to 4” piercing tools and blowing out irrigation systems. Designed with a simple push start control panel, the Viper™ is compact enough to fit into even the smallest pickup truck bed.

SPECIFICATIONS			
Model	D60	D70	D80
Capacity (CFM)	60	70	80 <small>(48 CFM at Idle)</small>
Air (PSI)	150	125 <small>(100 PSI at altitudes of 3500+ Ft.)</small>	100
Engine (RPM)	3600	3600	3600
Engine (HP)	24.8	24.8	24.8
Fuel Capacity	9 Gallon	9 Gallon	9 Gallon

Viper™ Diesel Unit Dimensions:  
 48L x 21W x 33H | Dry Weight (Lbs.): 735



### FEATURES

- Automatic Variable Speed Control Reduces Fuel Consumption
- 60 AMP Alternator
- Integrated Battery
- Cooling Baffle Ensures Proper Ventilation, to Protect the Machine from Debris and Reduce Noise
- Extra DC Power for Air After-Cooler Use
- Sized to Fit Behind the Cab or Side Pack

### AIR COMPRESSOR

- Lifetime Warranty on Air End
- Direct Drive - No Belts
- Oil Injected Rotary Screw Encapsulated Air End

### ENGINE

- Auto Shut Off and Start for Fuel Savings
- Kubota® Tier 4 Certified
- Diesel
- Liquid Cooled
- 3 Cylinder
- 24.8 HP
- 9 Gallon Fuel Tank
- Glow Plugs

### INSTRUMENTATION

- Conveniently Located Electronic Easy-To-Start Instrumentation Panel
- Features an Hour Meter, Pressure and Temperature Readout, Fuel Gauge and Engine RPM

### CANOPY

- Powder-Coated, Galvannealed Sheet Metal Enclosure
- Lifting Bail

### MAINTENANCE

- Easy Service Access - Removable Front Panel and Hinged Top for Serviceability
- Features an Hour Meter, Pressure and Spin-On Air-To-Oil Separating Element for Easy Maintenance

### SAFETY EQUIPMENT

- High-Temperature Shutdown Compressor and Engine
- Low Engine Oil Pressure Shutdown Air Pressure-Relief Safety Valve Minimum Pressure Valve
- Automatic Blowdown On Shutdown
- Oil Fill Plug Safety Relief
- High Pressure Shutdown for Compressor

### OPTIONS/ACCESSORIES

- Service/Control Line Moisture Separators
- Filter/Lubricator/Regulator (FLR)
- Air Hoses, Hose Reels, and Fittings
- OSHA Safety Valve (Velocity Fuse)
- Tool Oiler/Lubricator
- Cold Weather Package to Prevent Freeze-Ups
- Remote Instrument Panel
- Air After Cooler
- Remote Fuel Tank Option
- Maintenance Kits
- Hand Cart

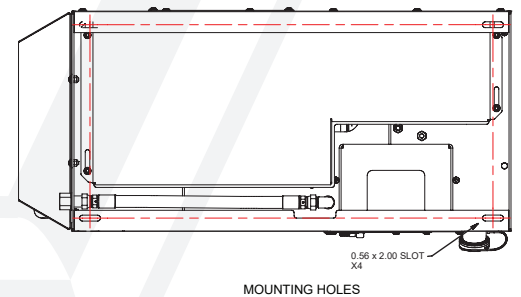
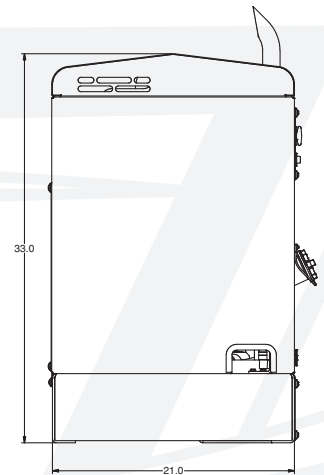
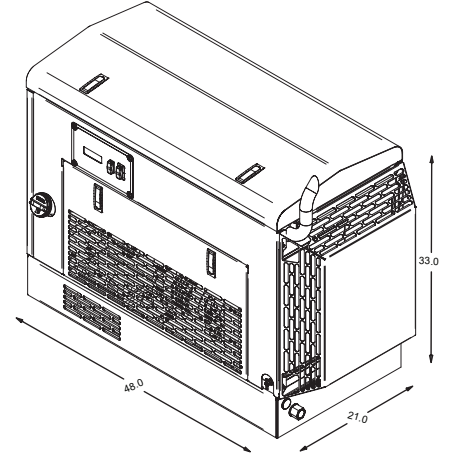

Vanair® reserves the right to make changes in engineering, design, and specifications; add improvements; or discontinue manufacturing at any time without notice or obligation. Vanair®, the Vanair® logo and MOBILE POWER SOLUTIONS® are registered trademarks or trademarks of Vanair® Manufacturing, Inc., Michigan City, IN, USA. © 2023 All Rights Reserved.