



PRO 35

 AIR COMPRESSOR

Rugged, Powerful, and Dependable Day After Day!

Vanair's PRO 35 reciprocating compressor package was developed to meet the demands of customers that need the convenience of mobile air at an economical cost. Designed to provide rugged, powerful, and dependable performance. These compressors are a perfect fit for the mechanic, service, agriculture, and contractor markets.

SPECIFICATIONS	
Compressor Type	Reciprocating
Capacity (CFM)	35 CFM
Air Pressure (PSI)	175 PSI
Receiver Capacity	30 Gal.
Engine Type	11.7 HP Honda® GX390 Electric Start*
Fuel Capacity	1.6 Gal.

PRO 35 Unit Dimensions with fittings (In.): 47L x 19W x 43H | Dry Weight (Lbs.): 460
 * Battery not included

PRO 35

AIR COMPRESSOR

- Reciprocating
- 35 CFM, Up to 175 PSIG
- 2-Cylinder
- Single Stage

ENGINE

- 11.7 HP Honda® GX390
- Electric Start with Recoil Back-up
- 1.6 Gal. Fuel Tank
- Gasoline Fuel

INSTRUMENTATION

- Air Pressure Gauge

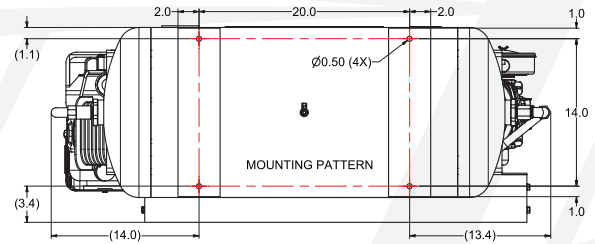
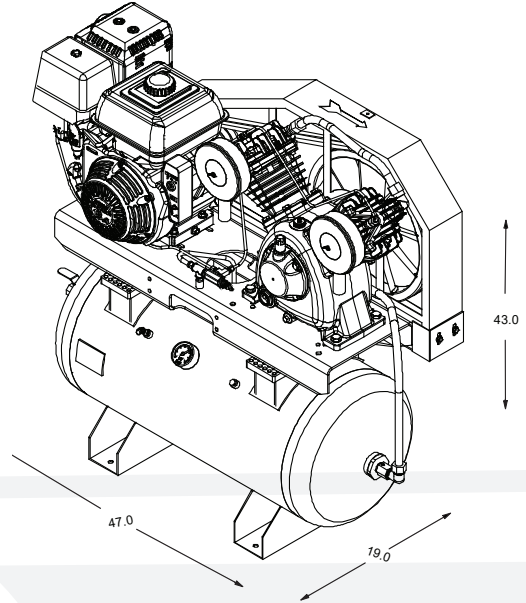

VAN AIR
MOBILE POWER SOLUTIONS

800.526.8817 | vanair.com

10896 West 300 North | Michigan City, Indiana 46360 USA



PRO35_032024_NML