



AIR N ARC 150

*Shown:
Vanair® VNR680
20 HP Model



AIR COMPRESSOR



GENERATOR



WELDER



BATTERY BOOST
(OPTIONAL)



BATTERY CHARGE
(OPTIONAL)

The ALL-IN-ONE Power System® for Light to Medium Industrial Repair.

The Air N Arc® 150 provides you with up to five forms of power in one compact and economic unit, allowing you to save space and weight on your vehicle. Providing up to 190 Amps of welding power, the Air N Arc® 150 is available in multiple configurations to meet your mounting needs.

SPECIFICATIONS	
Engine	Kohler® 14 HP or Vanair® VNR680 20 HP
Air Compressor	Reciprocating, 150 PSI, 20 CFM
Generator	5kW Peak / 4.2kW Continuous, AC Power, 60 Hz, Single Phase, 120V and 240V Outlets
Welder	14 HP Stand-Alone: CC: 40-190A Operating Range 20 HP with Remote Panel: CC: 40-150A, CV: 15-30V
Battery Boost/ Battery Charge	150A, 12/24V Boost and 50A, 12V Charge (Standard for Vanair® VNR680 20 HP Engine Only)
Drive System	Belt Driven
Fuel Capacity	1.9 Gal. (Kohler® 14 HP) 4.5 Gal., 11.5 Gal. or Tied to Chassis (Vanair® VNR680 20 HP)

Air N Arc® 150 Unit Dimensions with Fittings (In.):
51.5L x 21.0W x 31.2H - 10 Gal. Kohler® 14 HP
50.7L x 19.2W x 40.8H - 30 Gal. Kohler® 14 HP
50.3L x 18.2W x 24.2H - Skid Mount Kohler® 14 HP

47.8L x 22.8W 41.8H - 30 Gal. Vanair® VNR680 20HP
47.8L x 21.3W 25.3H - Skid Mount Vanair® VNR680 20HP



Dry Weight (Lbs): 290-487 (Depending on Machine)

PERFORMANCE/FEATURES

- Fuel System can be Integrated with the Chassis (Vanair® VNR680 20 HP Only)
- Powder Coated Sheet Metal for Protection
- 100% Duty High Frequency Welder Offering Excellent Weld Characteristics
- Galvannealed Steel Metal
- Heavy Duty Belt Driven System for Anti-Vibration and Long Service Intervals

AIR COMPRESSOR

- Reciprocating Compressor
- Cast Iron Air Pump with Three Cylinder Head Design for Better Cooling
- Factory Set @ 130 PSI (Adjustable to 150 PSI)

WELDER

- Patented Amperage and Power Controls Built Into Welding Lead for Ease of Use for Kohler® 14 HP Unit
- 100% Variable Completely Controllable
- Independent Welding Generator
- CV on Remote Panel Machines
- Safe Multi-Function
- Auto Throttle Control

GENERATOR

- True Two-Generator System for Safe Multi-Functioning of Welder and Electric Tools
- Brushless Design (AC)
- Smooth Wave for Minimal Distortion
- Two 120V Outlets and One 240V Outlet Provided

ENGINE

- Kohler® 14 HP or Vanair® VNR680 20 HP
- Electric Start

AVAILABLE FUEL CAPACITY

- 1.9 Gallons (Kohler® 14 HP)
- 11.5 Gallons on Models with 30 Gallon Air Storage (Vanair® VNR680 20 HP Only)
- Tied to Chassis

BATTERY BOOST/CHARGE (OPTIONAL)

- 150A, 12/24V Boost (Standard on Remote Control Panel)
- 50A, 12V Charge (Standard on Remote Control Panel)

REMOTE CONTROL PANEL (OPTIONAL)

- Optional on Vanair® VNR680 20 HP Systems Only (Harness Not Included)
- Provides Ultimate User Convenience and Safety
- All Functions Accessible at Panel

AVAILABLE AIR RESERVOIRS

- 10 Gallon (14 HP), 30 Gallon, and Skid Mount

OPTIONS/ACCESSORIES

- Remote Panel Harness - 10', 14', 18'
- Remote Mount Control Panel (Vanair® VNR680 20 HP Only)
- Battery Cable Extension - 8', 12', 16', 20', 24'
- Battery Booster Cables
- Fuel Tank – Slim Line 11 Gallon (Vanair® VNR680 20 HP Only)
- Remote Air Tank Options
- Remote Condensation Drain
- Welding Helmet with Auto Darkening Lens
- Dry Cell Battery
- GFCI Outlet for Protection of 120/240V (Remote Panel Machines Only)
- Filter/Lubricator/Regulator (FLR)
- Hose Reels and Fittings
- OSHA Safety Valve (Velocity Fuse)
- Service/Control Line Moisture Separators
- Tool Oiler/Lubricator
- Cold Weather Kits
- Maintenance Kits
- Hose Reels

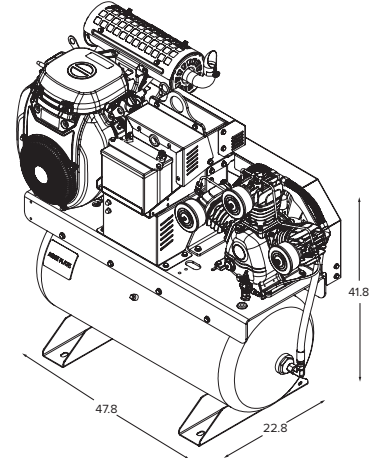

20 HP WITH 30 GALLON TANK

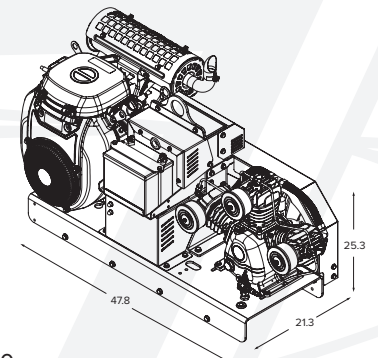

20 HP SKID MOUNT

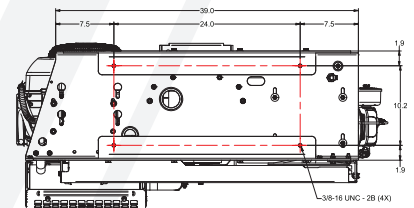

20 HP SKID MOUNT MOUNTING HOLES

Vanair® reserves the right to make changes in engineering, design, and specifications; add improvements; or discontinue manufacturing at any time without notice or obligation. Vanair®, the Vanair® logo and MOBILE POWER SOLUTIONS® are registered trademarks or trademarks of Vanair® Manufacturing, Inc., Michigan City, IN, USA. © 2024 All Rights Reserved.



VANAIR®
MOBILE POWER SOLUTIONS®

800.526.8817 | vanair.com