



CAP-START 
Goodall
 3000 A • 12/24V • 24 CFM • L

The Fastest and Lightest Instantaneous Engine Starting System on the Market!

The new lightweight, 30-gallon, Cap-Start® 3000 + Air Light allows you to rapidly start multiple vehicles in succession and provide the air power you need! Utilizing revolutionary new Vanair® Fast Start and Super Capacitor (VSC™) technology, Vanair's Cap-Start® 3000 + Air Light provides you with instantaneous starting power for all your heavy duty machinery, company fleets, and off road vehicles, keeping you up and running. No more waiting for your batteries to charge — getting you back to work in mere seconds. The Cap-Start® 3000 + Air Light is the fastest vehicle starting system on the market, offering:

- 3000+ AMPS of Instantaneous Starting Power
- 12/24V Charging and Starting Capabilities
- 24 CFM and Up to 175 PSIG of Air Power for All Your Pneumatic Tool Needs
- 240A Self-Regulating Alternator for Fast Recharging
- Innovative Vanair® Super Capacitor™ (VSC™)

SPECIFICATIONS	
12/24V Starting	Up to 3240A of Starting Capability
DC Alternator	240A @ 12/24V
Compressor Type	Reciprocating
CFM Rating	24 CFM
Air Pressure	175 PSIG Max
Engine Type	22.1 HP Honda® IGX700 EFI ETB
Drive System	Dual V-Belt
Fuel Type	Gasoline
Fuel Capacity	Optional Remote 11-Gal. Tank

PROTECT-ALL  **Look for the logo that delivers built-in safety!**
 Safety Technology *The innovations in safety technology include: reverse polarity, low voltage protection, short circuit, overheat protection, over discharge protection, over voltage protection, and open-clamp protection.*

Cap-Start® 3000 + Air Light Unit Dimensions with Fittings (In.):
 45.7L x 22.8W x 25.4H | Dry Weight (Lbs.): 360 | Skid Mount
 46.7L x 23.4W x 42.7H | Dry Weight (Lbs.): 479 | 30-Gallon Tank Mount

PERFORMANCE

- Vanair® Super Capacitor™ (VSC™)
- 3000 + AMPS Starting Capability
- 12/24V Charge/Start
- 240A Infinitely Variable Alternator
- 2-Stage Reciprocating Air Compressor
- Up to 24 CFM and 175 PSIG
- Unloader Valves
- Electronic Fuel Injected Honda® 22.1 HP IGX700 EFI ETB
- Automatic Electronic Throttle Control
- Heavy-Duty Belt Drive System

STARTING CABLES

- 30 Feet of 3/0 Polar-Grade Starting Cable
- UL/AWG Specification Compliant
- Fine Stranded, Flexible Copper
- Cold Weather Flexibility
- Tangle Resistant
- Chemical, Abrasion and Water Resistant
- Extruded Polarity Stripe for Safety Identification

CONTROL PANEL

- Color LED Digital Display
- Engine Start/Stop Function
- Hour Meter
- Voltage and Amperage Output Display
- Battery Charge/Start Mode Function
- Integrated Fault Codes and Warnings
- Fault Level (If Applicable)

CONVENIENCE

- Fully Powder Coated Aluminum Enclosure
- Aluminum Enclosure Around Electrical or Critical Components
- 3/16" Thick Steel Frame
- Optional Removable Lifting Eye
- Easy Service Access

SAFETY

- Weather Resistant Electrical Enclosure
- Smart, Self-Regulating Charging System
- Protect•All® Safety Technology and Fault Codes

OPTIONS/ACCESSORIES

- Remote Panel Connection Harness in Multiple Lengths
- Industrial 3/0 Polar-Grade Starting Cables (25, 30, 35 and 40 ft. Lengths)
- Bumper/Remote-Mount Start Receptacles
- Vibration Isolators
- Remote Air Tanks
- Remote Fuel Tank
- Remote Battery Box and Battery Kits
- Cable Kits for Connection to the Chassis Battery
- Maintenance Kit
- Cold Weather Kits
- California CARB Compliance Kits

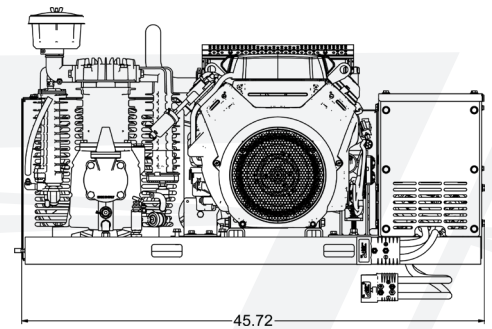
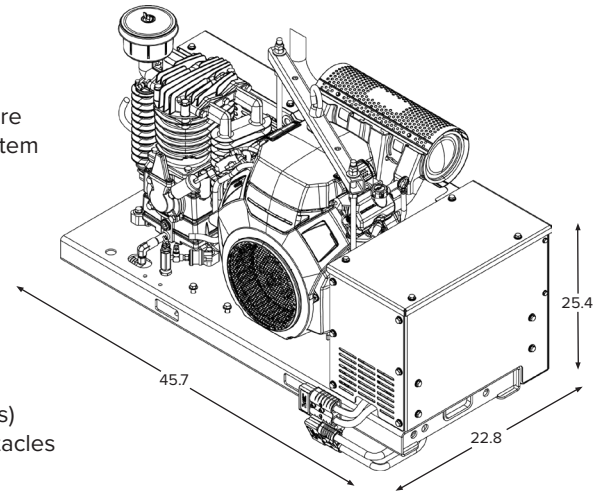

SKID MOUNT VERSION

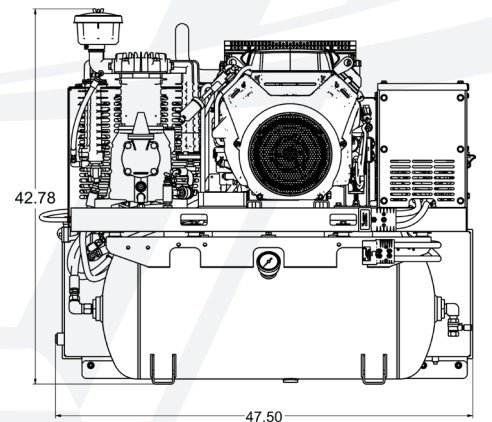

30-GALLON TANK MOUNT VERSION

Vanair® reserves the right to make changes in engineering, design, and specifications; add improvements; or discontinue manufacturing at any time without notice or obligation. Vanair®, the Vanair® logo and MOBILE POWER SOLUTIONS® are registered trademarks or trademarks of Vanair® Manufacturing, Inc., Michigan City, IN, USA. © 2024 All Rights Reserved.



VAN AIR®
MOBILE POWER SOLUTIONS®

800.526.8817 | vanair.com