



CAP-START
 3000 A • 12/24V

Dependable, Hydraulically Driven, Instantaneous Engine Starting!

The all-new revolutionary Vanair® Cap-Start® 3000 Hydraulic delivers instantaneous starting power for all of your vehicle needs, including heavy-duty machinery, company fleets, and off-road vehicles in a compact design. Ideally suited for mounting on trucks already equipped with a PTO hydraulic pump, the Cap-Start® 3000 Hydraulic can easily be mounted in a side pack of the truck. The Cap-Start® 3000 Hydraulic is packed with power to get you back on the road fast, offering:

- Reduced Weight, Maintenance, Space Requirement, and Noise
- 3000+ AMPS of Instantaneous Starting Power
- 12/24V Charging and Starting Capabilities
- 240A 3-Stage Alternator for Fast Recharging
- Industry-Leading Vanair® Super Capacitor™ (VSC™)

SPECIFICATIONS	
12/24V Starting	Up to 3240A of Starting Capability
Drive Type	Hydraulic
Hydraulic Requirements	8-12 GPM @ 3000 PSI
Motor	Gear Motor
Drive System	V-Belt
Battery	Vehicle Chassis
DC Alternator	240A, 12/24V

Cap-Start® 3000 Hydraulic Unit Dimensions with Fittings (In.): 25L x 18W x 12H
 Dry Weight (Lbs): 150 (cables not included in weight)

PROTECT-ALL
 Safety Technology

Look for the logo that delivers built-in safety!
 The innovations in safety technology include: reverse polarity, low voltage protection, short circuit, overheat protection, over discharge protection, over voltage protection, and open-clamp protection.

PERFORMANCE

- Vanair® Super Capacitor™ (VSC™)
- 3000+ AMPS Starting Capability
- 12/24V Charge and Start
- 240A 3-Stage Alternator
- Hydraulic Gear Motor
- Heavy-Duty Belt Drive System

STARTING CABLES

- 30 Feet of 3/0 Polar-Grade Cable
- UL/AWG Specification Compliant
- Fine Stranded, Flexible Copper Wire
- Cold Weather Flexibility
- Tangle Resistant
- Chemical, Abrasion and Water Resistant
- Extruded Polarity Stripe for Safety Identification

CONTROL PANEL

- Motor Start/Stop Function
- Hour Meter
- Voltage Output Display
- Charge/Start Mode Selector
- Mode Indicator Lights
- System Fault Lights

CONVENIENCE

- Fits Inside Many Side Compartments
- Tough, Powder Coated Sheet Metal
- Lightweight Aluminum Canopy
- Anderson Connector at Machine

SAFETY

- Weather-Protected Electrical Enclosure
- Reverse Polarity Protection
- Open, Closed or Low Circuit Safety
- Smart, Self-Regulating 3-Stage Charging System

OPTIONS/ACCESSORIES

- Industrial 3/0 Starting Cables (25, 30 and 35 Ft. Lengths)
- Vibration Isolators
- Cable Kits for Connection to the Chassis Battery
- Maintenance Kit
- Remote Control Panel

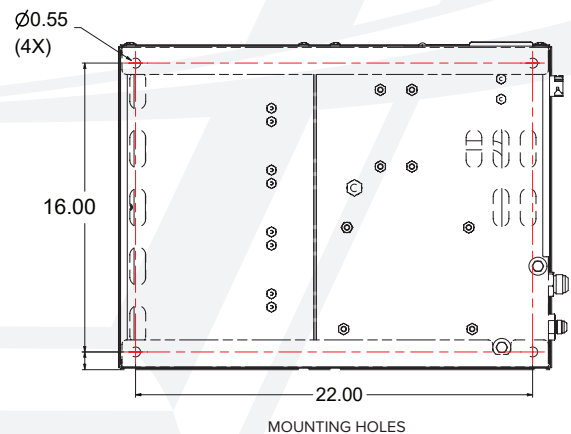
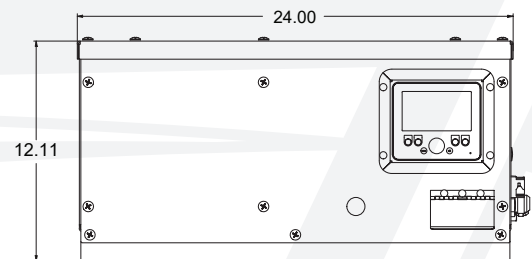
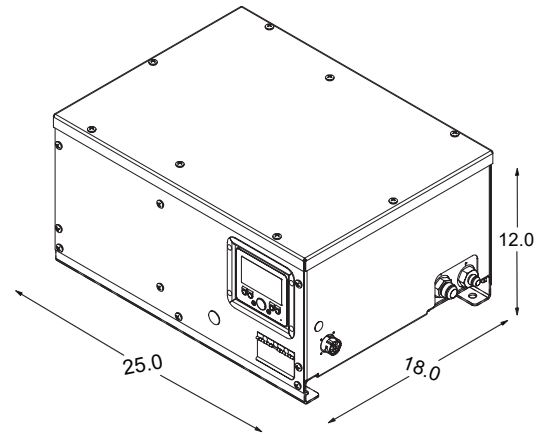

Vanair® reserves the right to make changes in engineering, design, and specifications; add improvements; or discontinue manufacturing at any time without notice or obligation. Vanair®, the Vanair® logo and MOBILE POWER SOLUTIONS® are registered trademarks or trademarks of Vanair® Manufacturing, Inc., Michigan City, IN, USA. © 2024 All Rights Reserved.