



CAP·START 
 3000 A · 12/24V

Don't Let A Dead Battery Ruin Your Work Day!

Inevitably, batteries fail, but that doesn't mean work has to stop. The all-new revolutionary Vanair® Cap·Start® 3000 delivers instantaneous starting power for all of your vehicle needs, including heavy-duty machinery, company fleets, and off-road vehicles. Completely portable, the Cap·Start® 3000 goes wherever you need it to go. Plus, with our innovative fast-charging Vanair® Super Capacitor™ (VSC™), you can now start vehicle after vehicle within seconds of each other, eliminating lengthy lag time. The Cap·Start® 3000 offers:

- 3000+ AMPS of Instantaneous Starting Power
- 12V and 12/24V Charging and Starting Capabilities
- 240A 3-Stage Alternator for Fast Recharging of the Capacitor
- Industry-leading Vanair® Super Capacitor™ (VSC™)
- Cap·Start® 3000 + Air Also Available, Featuring a 24 CFM Reciprocating Air Compressor

SPECIFICATIONS	
12V and 12/24V Starting	Up to 3240A of Starting Capability
Fuel Capacity	Integrated 1.725 Gallon Tank
Fuel Type	Gasoline
Engine Type	14.5 HP* Briggs & Stratton®
Drive System	V-Belt
Battery	Integrated
DC Alternator	240A, 12/24V

Cap-Start® 3000 Unit Dimensions with Fittings (In.): 36L x 21W x 20H
 Dry Weight (Lbs): 295 (cables not included in weight)



Look for the logo that delivers built-in safety!
 The innovations in safety technology include: reverse polarity, low voltage protection, short circuit, overheat protection, over discharge protection, over voltage protection, and open-clamp protection.

PERFORMANCE

- Vanair® Super Capacitor™ (VSC™)
- 3000 + AMPS Starting Capability
- 12V and 12/24V Charge and Start
- 240A 3-Stage Alternator
- 14.5 HP Briggs & Stratton®
- Heavy-Duty Belt Drive System

STARTING CABLES

- 30 Feet of 3/0 Polar-Grade Cable
- UL/AWG Specification Compliant
- Fine Stranded, Flexible Copper Wire
- Cold Weather Flexibility
- Tangle Resistant
- Chemical, Abrasion and Water Resistant
- Extruded Polarity Stripe for Safety Identification

CONTROL PANEL

- Engine Start/Stop Function
- Hour Meter
- Voltage Output Display
- Charge/Start Mode Selector
- Mode Indicator Lights
- System Fault Lights

CONVENIENCE

- Integrated Lifting Points
- Tough, Powder Coated Sheet Metal
- Corrosion-Resistant Galvanneal Steel Canopy
- Anderson Connector at Machine
- Gasoline Fuel

SAFETY

- Weather-Protected Electrical Enclosure
- Reverse Polarity Protection
- Open, Closed or Low Circuit Safety
- Low Engine Oil Pressure Shut Down
- Engine Over Temperature Shut Down
- Smart, Self-Regulating 3-Stage Charging System

OPTIONS/ACCESSORIES

- Industrial 3/0 Starting Cables (25, 30 and 35 ft. Lengths)
- Vibration Isolators
- Cable Kits for Connection to the Chassis Battery
- Maintenance Kit
- Cold Weather Kits
- 24 CFM Air Compressor

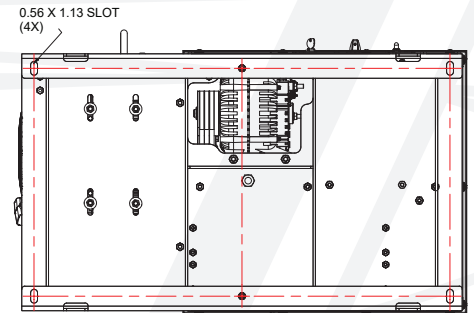
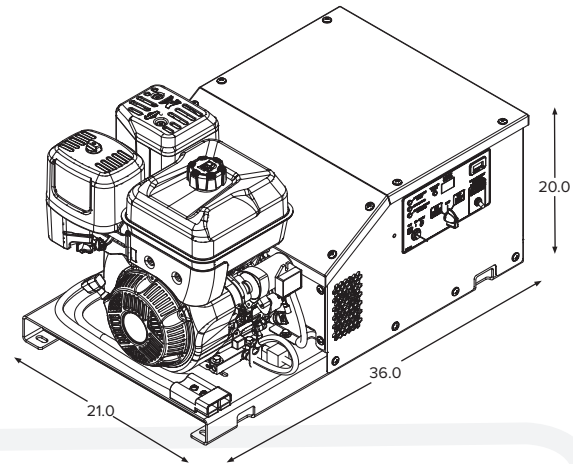

MOUNTING HOLES

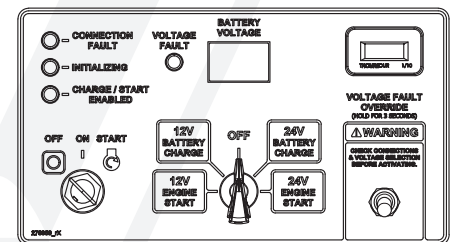

CONTROL PANEL

Vanair® reserves the right to make changes in engineering, design, and specifications; add improvements; or discontinue manufacturing at any time without notice or obligation. Vanair®, the Vanair® logo and MOBILE POWER SOLUTIONS® are registered trademarks or trademarks of Vanair® Manufacturing, Inc., Michigan City, IN, USA. © 2024 All Rights Reserved.