



\*Shown:  
Optional Wheel Cart

**VIPER**   
GAS

 AIR COMPRESSOR

## Power, Efficiency, and Reliability for Every Job Site!

The Viper™ Gas Rotary Screw Air Compressor allows you to get in and out of the job site fast. With a large fuel tank designed for up to six and a half hours of runtime at a 70% duty cycle, this unit allows you to power through multiple projects without the need to stop for refueling. Its compact footprint saves valuable trailer or truck bed space for more tools. Low idle RPMs reduce noise, providing a quieter experience for you to work in. As if that wasn't enough, sensors automatically unload the compressor during startup, and the auto start-stop turns on with air demand. The heavy-duty 80 CFM and 100 PSI air pressure make this unit the ideal choice to operate: 90 Lb. jackhammers, 4" piercing tools, pavement breaking, monument engraving, irrigation services, post-pounding, directional boring, and more.

	SPECIFICATIONS		
Model	G60	G70	G80
Capacity (CFM)	60	70	80
Air (PSI)	150	125	100
Engine (RPM)	3600	3600	3600
Engine (HP)	Honda® 25	Honda® 25	Honda® 25
Fuel Capacity	10 Gallon	10 Gallon	10 Gallon

Viper™ Gas Unit Dimensions (In.): 39L x 21W x 30H | 40L x 25W x 32H With Fittings | Dry Weight (Lbs.): 440



### AIR COMPRESSOR

- Lifetime Warranty
- Rotary Screw
- Vanair® Encapsulated Air End
- Belt-Driven

### ENGINE

- Honda® iGX800 EFI, 25 HP
- Gasoline
- 4-Cycle, V-Twin, Overhead Valve
- 10 Gal. Fuel Tank

### INSTRUMENTATION

- Temperature Indicator
- Engine Diagnostic Lamp
- Hour Meter
- Digital Pressure Display

### CANOPY

- Powder-Coated Galvanneal Sheet Metal
- Lifting Bail

### MAINTENANCE

- Easy Service Access
- Removable Panels and Hinged Top for Serviceability

### SAFETY EQUIPMENT

- Air Pressure-Relief Safety Valve
- Minimum Pressure Valve
- Automatic Blowdown on Shutdown
- Low Engine Oil Pressure Shutdown
- High Compressor Temperature and Pressure Shutdown

### OPTIONS/ACCESSORIES

- Remote Start/Stop
- Remote Dual Pressure
- Cold Weather Package
- Service/Control Line Moisture Separators
- Filter/Lubricator/Regulator (FLR)
- Tool Oiler/Lubricator
- Air Hoses, Hose Reels, and Fittings
- OSHA Safety Valve (Velocity Fuse)
- CARB Canister
- Maintenance Kits
- Wheel Cart
- Load Space Air Baffle

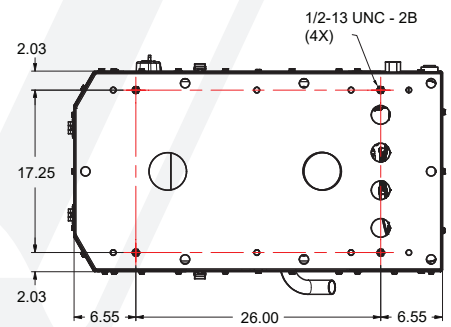
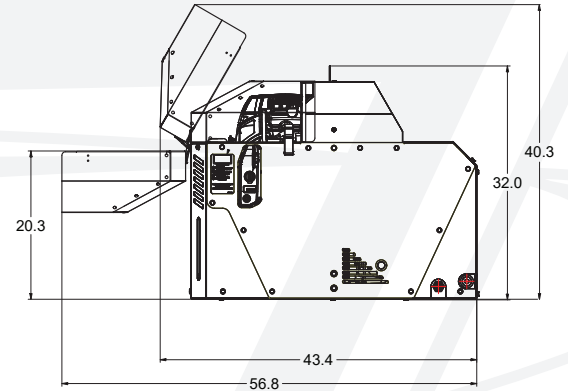
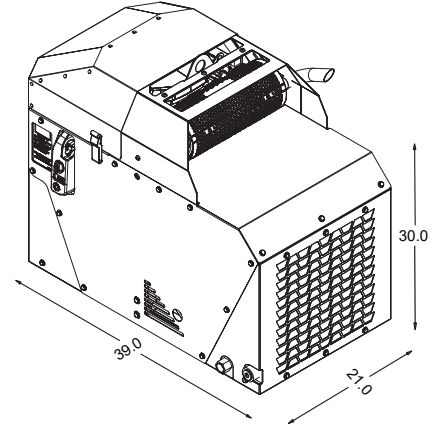

MOUNTING HOLES

Vanair® reserves the right to make changes in engineering, design, and specifications, add improvements, or discontinue manufacturing at any time, without notice or obligation. Vanair®, the Vanair® logo and MOBILE POWER SOLUTIONS® are registered trademarks or trademarks of Vanair®, a Lincoln Electric Company, Michigan City, IN, USA. © 2025 All Rights Reserved.

